



General Description

The OCH1902 is small, versatile linear Hall effect devices which are operated by the magnetic field from a permanent magnet or an electromagnet. They are optimized to accurately provide a voltage output that is proportional to an applied magnetic field. These devices have a quiescent output voltage that is 50% of the supply voltage.

The Hall-effect integrated circuit included in each device includes a Hall sensing element, a linear amplifier, and a CMOS Class AB output structure. Integrating the Hall sensing element and the amplifier on a single chip minimizes many of the problems normally associated with low voltage level analog signals.

High precision in output levels is obtained by internal gain and offset trim adjustments made at end-of-line during the manufacturing process.

The integrated circuitry provides increased temperature stability and sensitivity, for both linear target motion and rotational motion. These linear position sensors have an operating temperature range of -40°C to +150°C, appropriate for industrial environments. They respond to either positive or negative gauss, monitoring either or both magnetic poles. The quad Hall sensing element minimizes the effects of mechanical or thermal stress on the output. The positive temperature coefficient of the sensitivity helps compensate for the negative temperature coefficients of low cost magnets, providing a robust design over a wide temperature range.

The OCH1902 is available in small 3-pin SOT23-3L and SIP-3L package, and is rated over the -40°C to +150°C. These packages are available in a lead (Pb) free version.

Features

- Supply Voltage Range: 3.0V ~ 5.5V
- Fast Power-on Time
- Power Consumption of 8mA at 5V Supply Voltage
- Single Current Sinking or Current Sourcing Output
- Linear Output For Circuit Design Flexibility
- Ratio metric Output for A/D Interface
- Wide Sensible Magnetic Field Range on Different Supplied Voltage ± 450 Gauss on 5V Supplied Voltage
- Rail to Rail Operation Provides More Useable Signal For Higher Accuracy
- Temperature Stable Quiescent Output Voltage
- Quad Hall Sensing Element For Stable Output
- Low Noise Output
- Responds to Either Positive or Negative Gauss
- Robust EMC Protection
- Temperature Range of -40°C to +150°C
- Miniature Package SOT23-3L and SIP-3L

Applications

- Current Sensing
- Motor Control
- Linear Position Sensing
- Magnetic Code Reading
- Rotary Position Sensing
- Ferrous Metal Detector
- Vibration Sensing
- Liquid Level Sensing
- Weight Sensing

Pin Configuration

SOT-23-3L and SIP-3L (Top View)

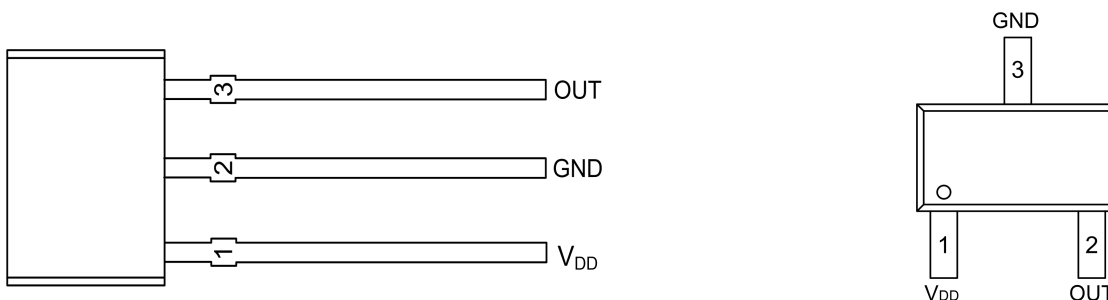

Figure 1, Pin Assignments of OCH1902

Pin Name	Pin No.		I/O	Pin Function
	SOT23-3L	SIP-3L		
VDD	1	1	P	Power Supply Pin.
GND	3	2	P	Ground Pin.
OUTPUT	2	3	O	Linear Voltage Output Pin.



■ Typical Application Circuit

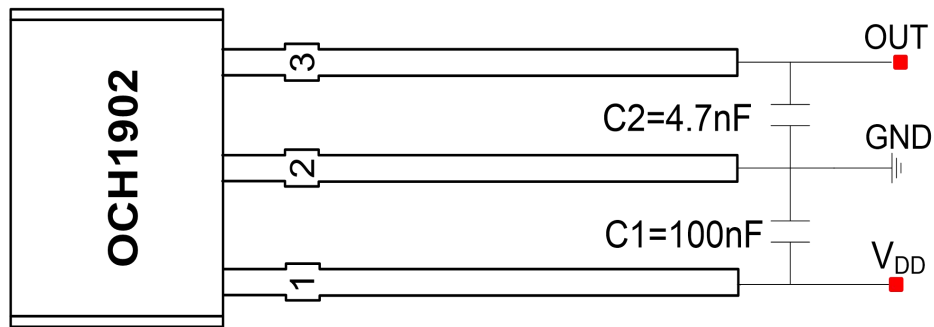
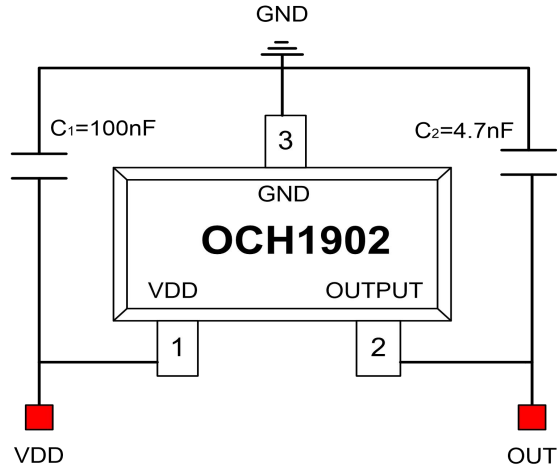

Figure 2, Typical Application Circuit