



ORIENT-CHIP

General Description

The OCH29891 is an integrated Hall sensor with H-Bridged output driver designed for brushless DC motor applications. The device is using HV process includes an one-chip Hall sensor for magnetic sensing, an amplifier that amplifies the Hall voltage, a comparator to provide switching hysteresis for noise rejection, a bi-directional drivers for sinking and driving large current load.

Placing the device in a variable magnetic field, if the magnetic flux density is larger than threshold BOP, the DO is turned to sink and DOB is turned to drive. This output state is held until the magnetic flux density reverses and falls below BRP, then causes DO to be turned to drive and DOB turned to sink.

OCH29891 is available in SIP-4L package and is rated over the -40°C to 125°C.

Features

- One-chip Solution (Hall Element + Driver)
- Continuous Output Current : 500mA
- High Sensitivity Hall Sensor  
BOP25GS、BRP-25GS
- Lock-shutdown protection & auto-restart function
- Thermal Shutdown Protection
- -40°C to +125°C Temperature Range
- RoHS Compliant
- Available in SIP-4L(TO94) Packages

Applications

- Single phase DC Brushless Fan
- Single phase DC Brushless Motor

Pin Configuration

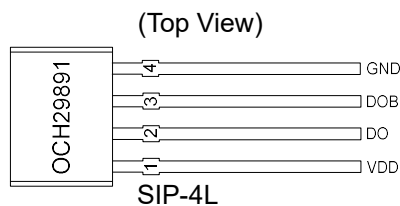

Figure 1, Pin Assignments of OCH29891

Pin Name	Pin Number	Pin Function
VDD	1	Positive Power Supply
DO	2	Output 1
DOB	3	Output 2
GND	4	Ground

Typical Application Circuit

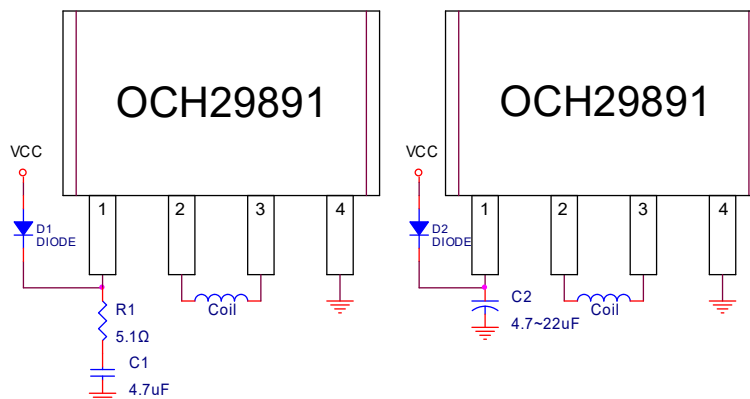

Figure 2, Typical Application Circuit of OCH29891

Note1:When the power pulse is relatively large, Must use least C1=4.7μF(ceramic capacitor) capacitor &R1=5.1Ω or C2=4.7~22μF for the decoupling between VDD and GND and place the capacitor as close to the IC as possible.



ORIENT-CHIP

■ Block Diagram

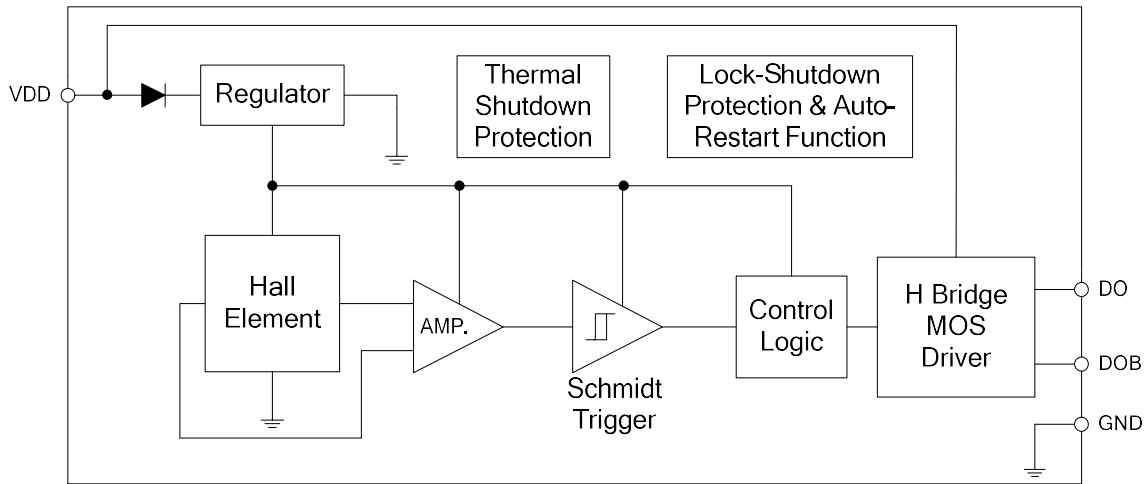

Figure 3, Block Diagram Of OCH29891