

Programmable Dual Output LCD Bias for Smartphone and Tablets

■ General Description

The OCP2130 is designed to support positive / negative driven TFT-LCD panels up to 10" at least (from SFF to MFF like tablets). The two output rails are usually connected to the Source Driver IC. The device uses a single inductor scheme in order to provide the user the smallest solution size possible as well as high efficiency.

It features a highly integrated step-up DC-DC converter with wide input voltage range from 2.7V to 5.5V. It is optimized for products powered by single-cell batteries (Li-Ion, Ni-Li, and Li-Polymer) and symmetrical output currents up to 80mA. An LDO and charge pump generate dual outputs at +5V (default) and -5V (default), whose voltages can be programmed via an I2C compatible interface. Optimized step-up, LDO and charge pump converters maximize conversion efficiency, exceeding 85%.

OCP2130 integrates all compensation and soft-start circuitry, which results in a simpler and smaller solution with much fewer external components. High switching frequency (1.2MHz) allows the use of a smaller inductor and capacitor to further reduce the solution size.

The I2C compatible interface allows to control the positive and negative outputs from +4V to +6V and -4V to -6V, respectively, as well as programming additional registers on the device.

The device is a RoHS compliant 15-Ball 2.1Xmm X 1.3Xmm X 0.6mm WLCSP and TDFN2.5X3-14L package.

■ Features

- Wide 2.7V to 5.5V Operating Input Range
- Dual Output Regulator with Single Inductor
- Programmable Output Voltage Voltages
- Positive Output Voltage Range: +4V to +6V (100mV/Step)
- Negative Output Voltage Range: -4V to -6V (100mV/Step)
- ±1.5% Output Voltage Accuracy
- Excellent Line Regulation
- Advanced Power-Save Mode for Light Load
- Support I2C Compatible Interface
- Integrated Compensation and Feedback Circuits
- 1uA Shut-Down Supply Current
- Boost Current Mode Operation
- Over Current Protection
- Internal Soft-Start Prevents Inrush Current
- Under Voltage Lock Out
- Thermal Shutdown
- Available in an 15-Ball WLCSP
- -40°C to +85°C Operating Temperature Range

■ Applications

- TFT LCD Smart-phones
- TFT LCD Tablets
- General Dual Power Supply Application

■ Pin Configuration

WLCSP-15 (Top View)

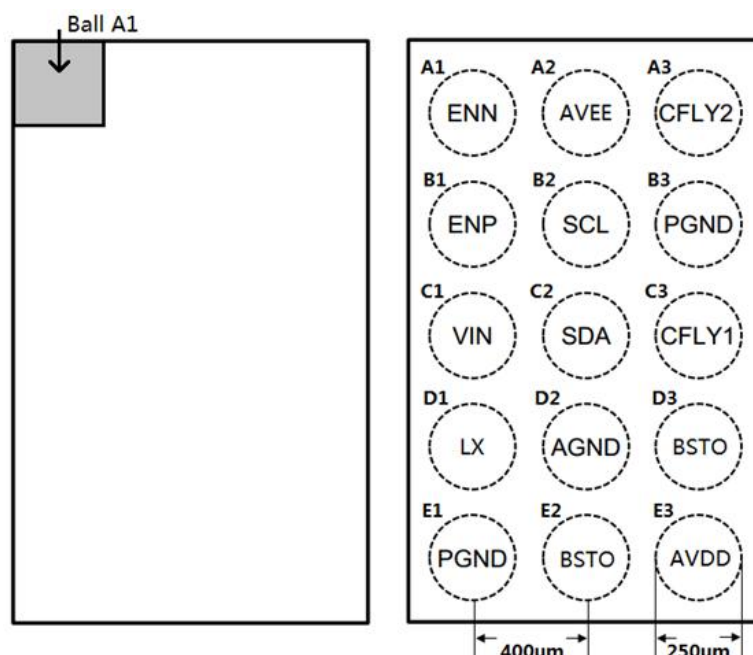

Figure 1, Pin Assignments of OCP2130

Pin Name	Pin No.	I/O	Pin Function
ENN	A1	I	Enable Input for negative output (AVEE). A logic high enable the negative Output, a logic low forces the output into shutdown mode reducing the supply current.
AVEE	A2	O	Charge pump output pin of the negative power.
CFLY2	A3	I/O	Negative charge pump flying capacitor pin.
ENP	B1	I	Enable Input for positive output (AVDD). A logic high enable the positive Output, a logic low forces the output into shutdown mode reducing the supply current.
SCL	B2	I/O	SCL clock input pin of I2C interface.
PGND	B3,E1	P	Power Ground.
VIN	C1	P	Input voltage supply pin. Connect a larger than 4.7uF capacitor to ground.
SDA	C2	I/O	SDA bi-direction data pin of the I2C interface
CFLY1	C3	I/O	Negative charge pump flying capacitor pin.
LX	D1	I/O	Switch pin of boost converter.
AGND	D2	P	Analog ground.
BSTO	D3,E2	I/O	Boost converter output pin.
AVDD	E3	O	Output pin of the LDO positive voltage.

■ Typical Application Circuit

Figure 2, Typical Application Circuit of OCP2130



■ Block Diagram

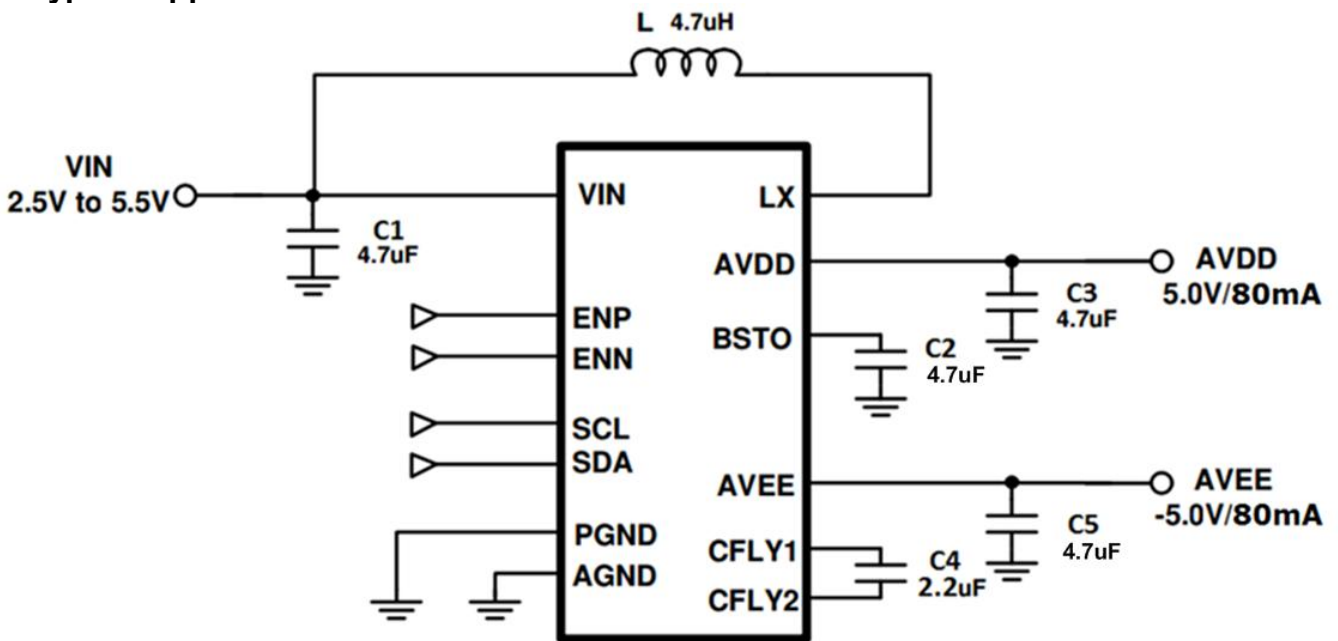
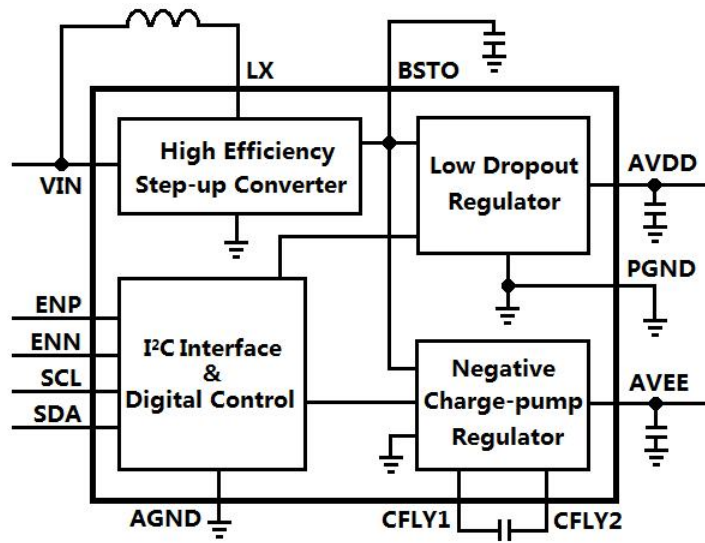

Figure 3, Block Diagram of OCP2130