



■ General Description

The OCA7192BAD is an audio power amplifier primarily designed for demanding applications in mobile phones and other portable communication device applications. It is capable of delivering 1.2 watts of continuous average power to an 8Ω BTL load and 1.5 watts of continuous average power to a 4Ω BTL load with less than 1% distortion (THD+N) from a 5V_{DC} power supply.

Boomer audio power amplifiers were designed specifically to provide high quality output power with a minimal amount of external components. The OCA7192BAD does not require output coupling capacitors or bootstrap capacitors, and therefore is ideally suited for mobile phone and other low voltage applications where minimal power consumption is a primary requirement.

The OCA7192BAD features a low-power consumption shutdown mode. To facilitate this, Shutdown may be enabled by either logic high or low depending on mode selection. Driving the shutdown mode pin either high or low enables the shutdown pin to be driven in a likewise manner to enable shutdown.

The OCA7192BAD contains advanced pop & click circuitry which eliminates noise which would otherwise occur during turn-on and turn-off transitions.

The OCA7192BAD is unity-gain stable and can be configured by external gain-setting resistors.

■ Features

- PSRR at 217Hz, V_{DC}=5V (Fig.1) 77dB(typ.)
- Power Output at 5.0V ,1% THD+N,4Ω 1.5W(typ.)
- Power Output at 5.0V ,1% THD+N,8Ω 1.2W(typ.)
- Power Output at 3.0V ,1% THD+N,4Ω 600mW(typ.)
- Power Output at 3.0V ,1% THD+N,8Ω 425mW(typ.)
- Shutdown Current 0.1μA(typ.)
- Available in space-saving package: micro SMD
- Ultra low current shutdown mode
- Improved pop and click circuitry eliminates noises during turn-on and turn-off transitions
- 2.2V - 5.5V operation
- No output coupling capacitors, snubber networks or bootstrap capacitors required
- Unity-gain stable
- External gain configuration capability
- User selectable shutdown High or Low logic Level

■ Applications

- Mobile Phones
- PDAs
- Portable electronic devices

■ Pin Configuration

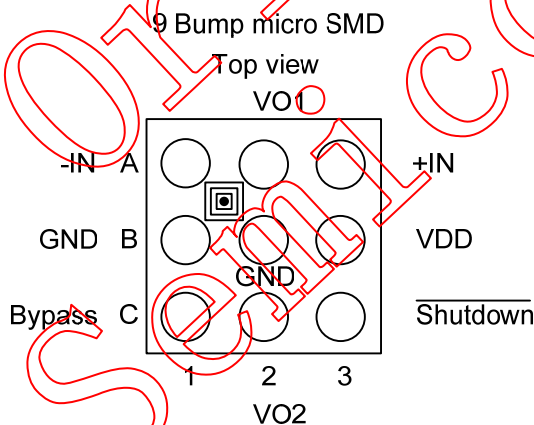

Contact Information:

For more detail information , please direct any inquiries and/or comments to info@orient-chip.com.



Pin Descriptions

Pin Name	Pin No.	I/O	Pin Description
-IN	A1	I	Negative differential input
+IN	A3	I	Positive differential input
VO1	A2	O	Negative BTL output
VO2	C2	O	Positive BTL output
VDD	B3	Power	Supply Voltage
Shutdown	C3	I	Shut down control, hold low for shutdown mode
Bypass	C1	I	Bypass capacitor which provides the common mode voltage
GND	B1,B2	Power	GND

Typical Application Circuit

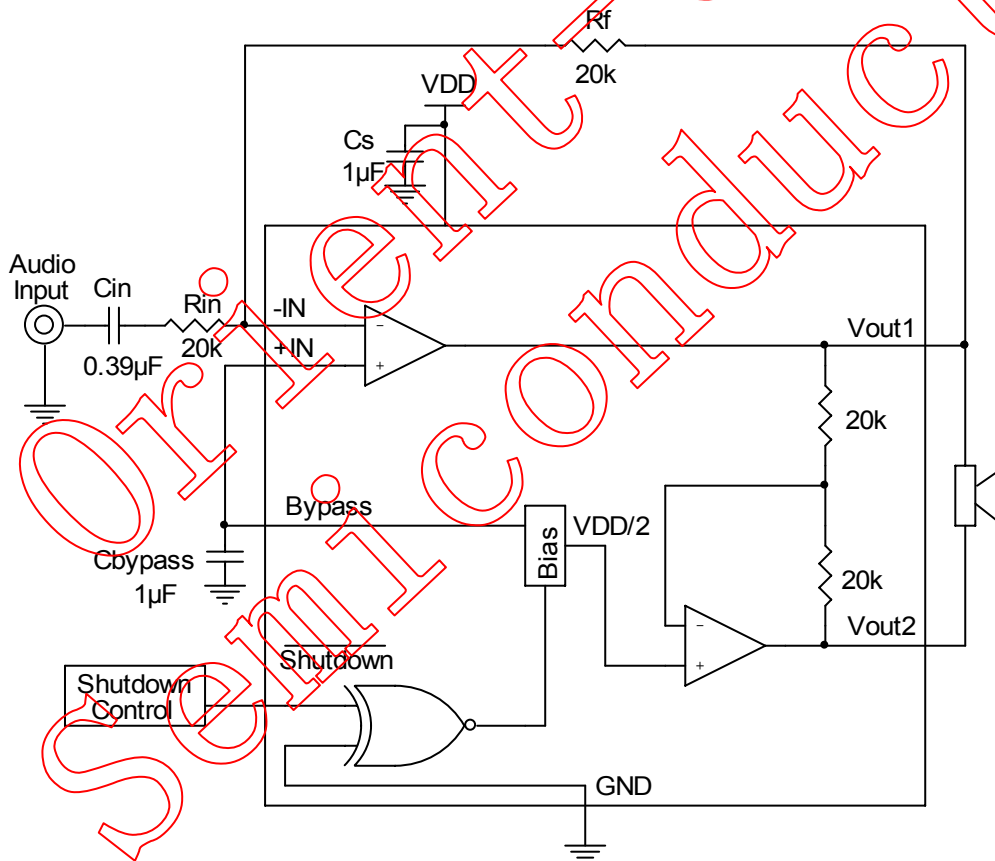

Figure 1 Typical Application Circuit

Contact Information:

For more detail information , please direct any inquiries and/or comments to info@orient-chip.com.