

■ General Description

The OCH1608 Omnipolar Hall effect sensor IC is fabricated from mixed signal CMOS technology. It is comprised of two Hall plates and a CMOS output driver, mainly designed for battery-operation. The total power consumption in normal operation is typically 2.4μW with a 3V power source. either north or south poles of sufficient strength will turn the output on. The output will be turned off under no magnetic field. While the magnetic flux density (B) is larger than operating point (BOP), the output will be turned on (low), the output is held until B is lower than release point (BRP), and then turned off.

The OCH1608 is available in many flexible packaging options, such as SOT23-3L/SIP-3L. Operating temperature range of the OCH1608 is from -40°C to 85°C.

■ Features

- **0.8uA** Micro power design
- Operation with North or South pole(omnipolar)
- CMOS Output
- 2.4V to 5.5V battery operation
- High sensitivity and high stability of the magnetic switching points
- High resistance to mechanical stress
- Digital output signal
- Good RF noise immunity
- -40°C to 85°C operating temperature
- SOT23-3L/SIP-3L(TO92S) package

■ Applications

- Smart meter
- toys
- Cover switch in Notebook PC/PDA
- Contact-less switch in consumer products
- Solid State Switch
- Handheld Wireless Handset Awake Switch
- Lid close sensor for battery-powered device
- Magnet proximity sensor for reed switch replacement in low duty cycle applications

■ Pin Configuration

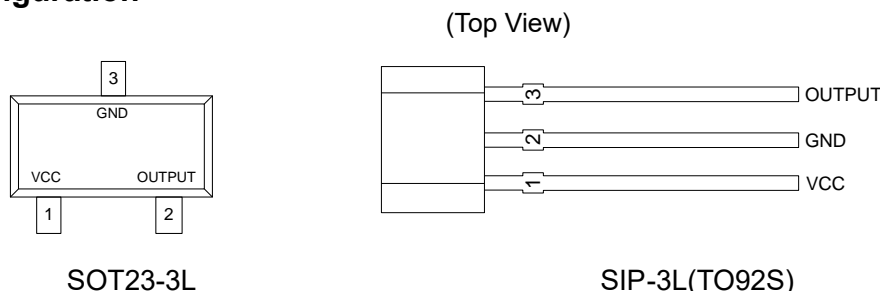

Pin Name	Pin		Description
	SOT23-3L	SIP-3L	
VCC	1	1	IC Power Supply
OUTPUT	2	3	It is low state during the S/N magnetic field
GND	3	2	IC Ground

■ Application Circuit

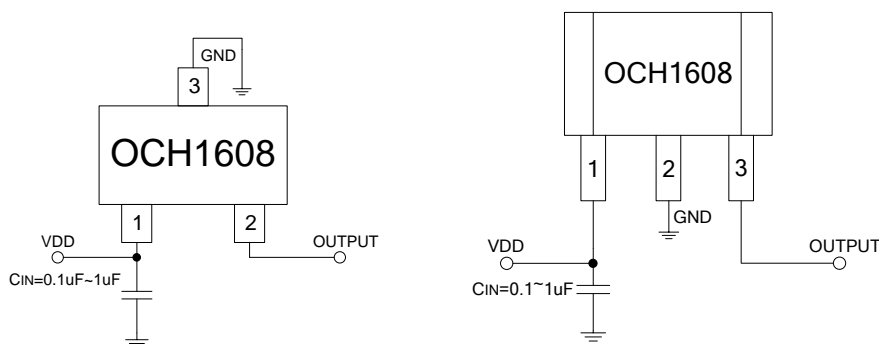

Figure 1, application circuit

Note: C_{IN} is for power stabilization and to strengthen the noise immunity, the recommended capacitance is 0.1~1uF.



■ **Ordering Information**

Part Number	Package Type	Packing Qty	B _{OP} (Gauss)	B _{RP} (Gauss)	Temperature	Eco Plan	Lead
OCH1608WAD	SOT23-3L	3000pcs/Reel	±35(Typ.)	±23(Typ.)	-40~ +85℃	ROHS	Cu
OCH1608MD	SIP-3L	1000pcs/Bag	±35(Typ.)	±23(Typ.)	-40~ +85℃	ROHS	Cu

■ **Block Diagram**

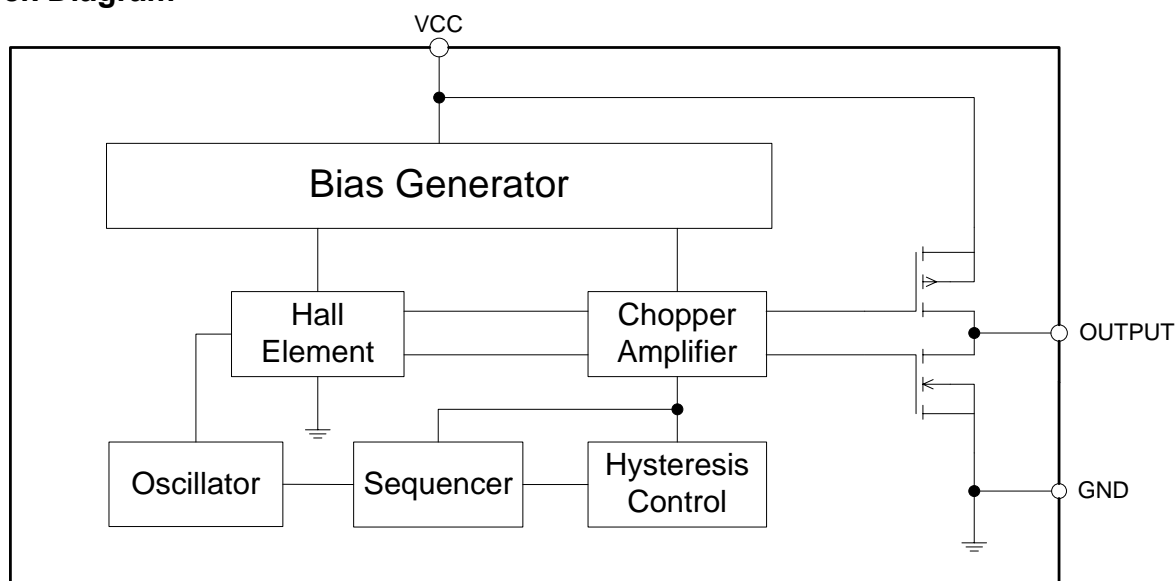

Figure 2, Block Diagram Of OCH1608

■ **Absolute Maximum Ratings**¹ (T_A=25℃ unless otherwise noted)

Parameter	Symbol	Rating	Unit
VDD to GND	V _{CC}	-0.3 to 6	V
Magnetic Flux Density	B	Unlimited	
Storage Temperature Range	T _S	-65 to +150	℃
Operating Junction Temperature Range	T _J	-40 to 150	℃
Maximum Power Dissipation	SOT23-3L	230	mW
	SIP-3L	300	
Maximum Soldering Temperature (at leads, 10 sec)	T _{LEAD}	260	℃

■ **Recommended Operating Conditions** (T_A=25℃ unless otherwise noted)

Parameter	Symbol	Conditions	Rating	Unit
Supply Voltage	V _{DD}	Operating	2.4 ~ 5.5	V
Operating Temperature Range	T _A	Operating	-40 ~ +85	℃



■ **Electrical Characteristics**

(Unless otherwise noted, typical values are at $T_A=25^{\circ}\text{C}$, $V_{DD}=3\text{V}$)

Symbol	Parameter	Conditions	Min.	Typ.	Max.	Unit
V_{OL}	Output On Voltage (Low side)	$I_{OUT}=-1\text{mA}$	-0.3	0.1	0.3	V
I_{OFF}	Output Leakage Current	$V_{OUT}=5.5\text{V}$, Output off	-	<0.1	1	μA
$I_{DD}(EN)$	Supply Current	Chip enable, $T_A=25^{\circ}\text{C}$, $V_{DD}=3\text{V}$	-	1.6	2.3	mA
$I_{DD}(EN)$		Chip enable, $T_A=-40\sim 85^{\circ}\text{C}$, $V_{DD}=2.4\sim 5.5\text{V}$	-	1.6	3	mA
$I_{DD}(DIS)$		Chip disable, $T_A=25^{\circ}\text{C}$, $V_{DD}=3\text{V}$	-	0.42	0.7	μA
$I_{DD}(DIS)$		Chip disable, $T_A=-40\sim 85^{\circ}\text{C}$, $V_{DD}=2.4\sim 5.5\text{V}$	-	0.42	1	μA
$I_{DD}(AVG)$		Average supply current, $T_A=25^{\circ}\text{C}$, $V_{DD}=3\text{V}$	-	0.8	1.5	μA
$I_{DD}(AVG)$		Average supply current, $T_A=-40\sim 85^{\circ}\text{C}$, $V_{DD}=2.4\sim 5.5\text{V}$	-	0.8	2.5	μA
T_{awake}		Awake Time	-	5	9.5	15
T_{period}	Period	-	20	40	60	ms
D.C.	Duty Cycle	-	-	0.024	-	%

■ **Magnetic Characteristics**

$V_{DD}=3\text{V}, T_A=25^{\circ}\text{C}$					
Parameter	Symbol	Min.	Typ.	Max.	Unit
South Pole Operate point	BOPS	20	35	55	Gauss
South Pole Release point	BRPS	10	23	50	Gauss
North Pole Operate point	BOPN	-55	-35	-20	Gauss
North Pole Release point	BRPN	-50	-23	-10	Gauss
Hysteresis	BHYS	5	12	20	Gauss

■ **Output VS Magnetic Pole**

Part Number	Magnetic Pole	Test Conditions	Output
OCH1608	South Pole	$B > \text{BOPS}$	Low
OCH1608	South Pole	$B < \text{BRPS}$	High
OCH1608	North Pole	$B < \text{BOPN}$	Low
OCH1608	North Pole	$B > \text{BRPN}$	High



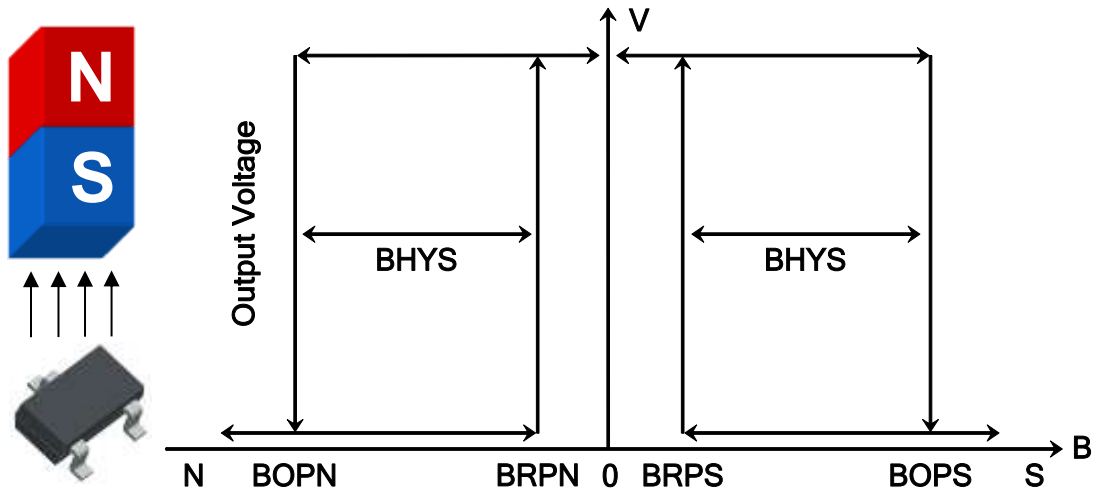

Figure 3, Magnetic Operational Characteristics Of OCH1608

■ **Hall Sensor Location**

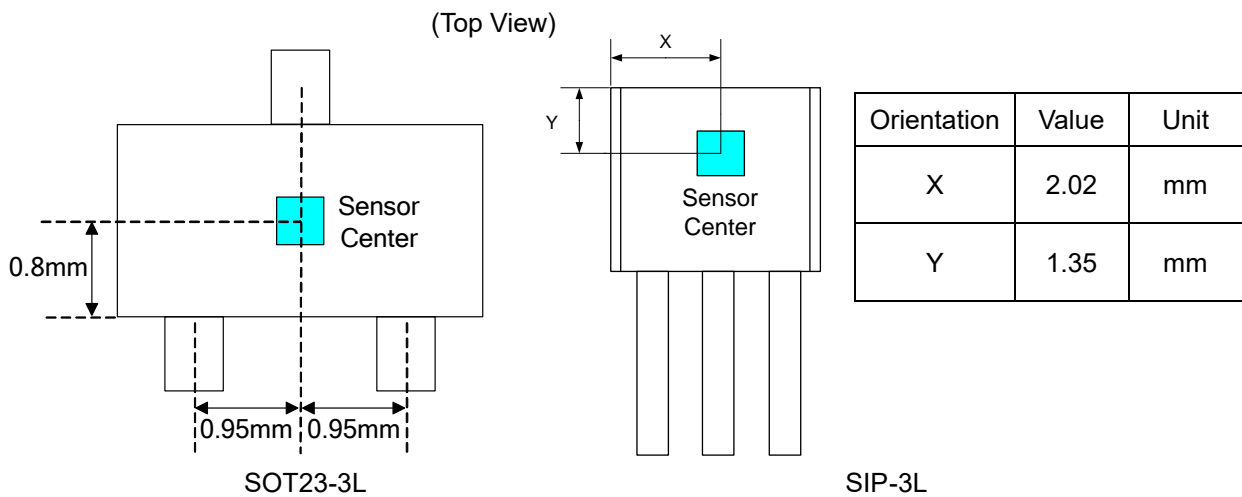

Figure4, Hall Sensor Location



■ Land Pattern (for reference only)

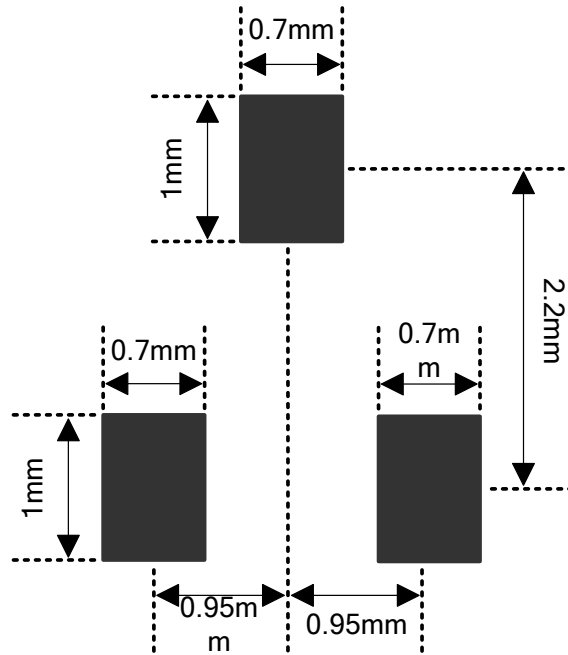
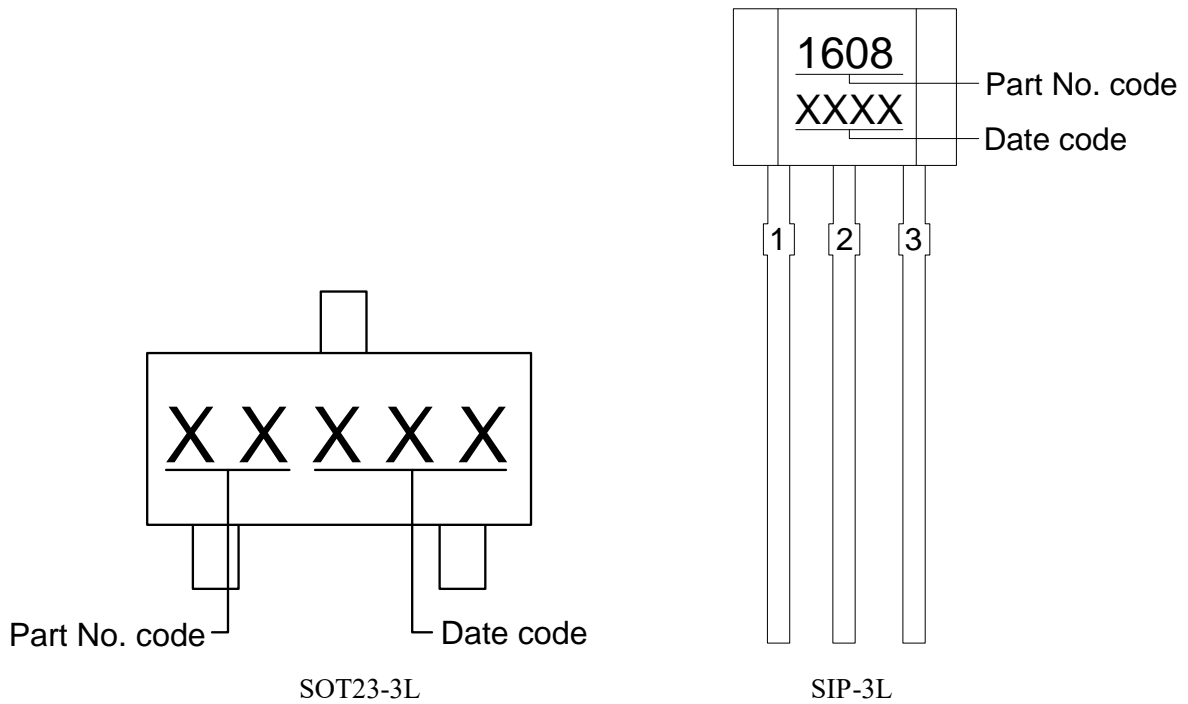

Figure 5, Land Pattern Dimension (SOT23-3L)

■ Marking Information

(Top View)



■ Package Information

1)SOT23-3L

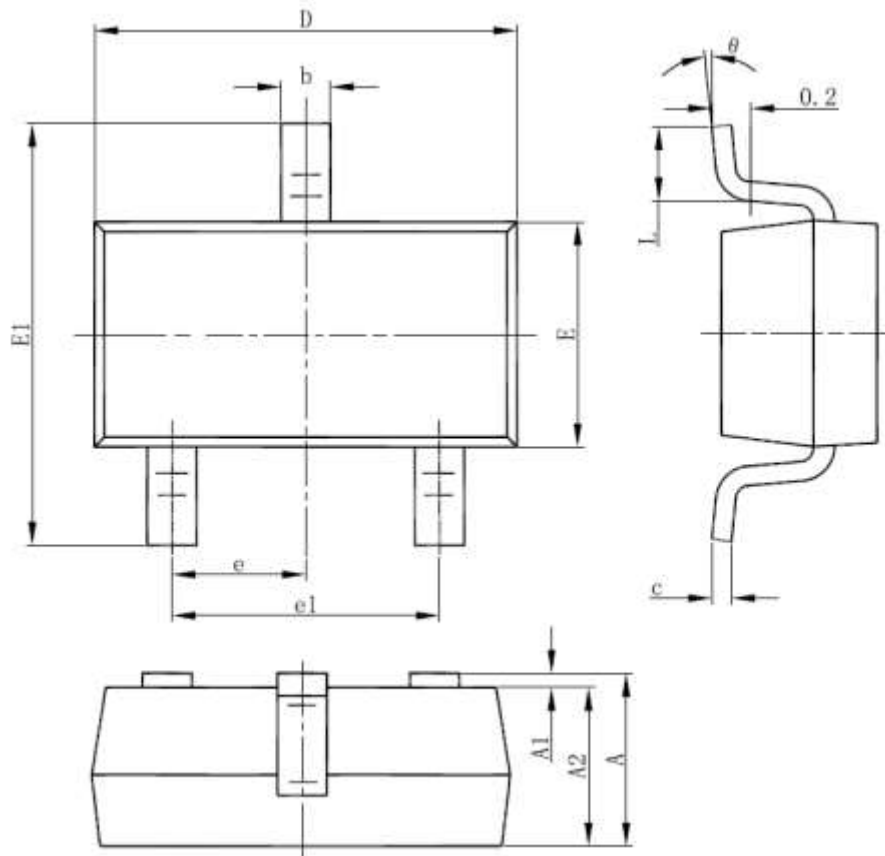

Symbol	Dimensions In Millimeters			Dimensions In Inches		
	Min.	Typ.	Max.	Min.	Typ.	Max.
A	1.050	1.15	1.250	0.041	0.045	0.049
A1	0.000	0.050	0.100	0.000	0.002	0.004
A2	1.050	1.100	1.150	0.041	0.043	0.045
b	0.300	0.400	0.500	0.012	0.016	0.020
c	0.100	0.150	0.200	0.004	0.006	0.008
D	2.820	2.920	3.020	0.111	0.115	0.119
E	1.500	1.600	1.700	0.059	0.063	0.067
E1	2.650	2.800	2.950	0.104	0.110	0.116
e1	1.800	1.900	2.000	0.071	0.075	0.079
e	0.950 REF			0.037 REF		
L	0.300	0.450	0.600	0.012	0.018	0.024
θ	0°	4°	8°	0°	4°	8°



■ **Package Information**

2)SIP-3L

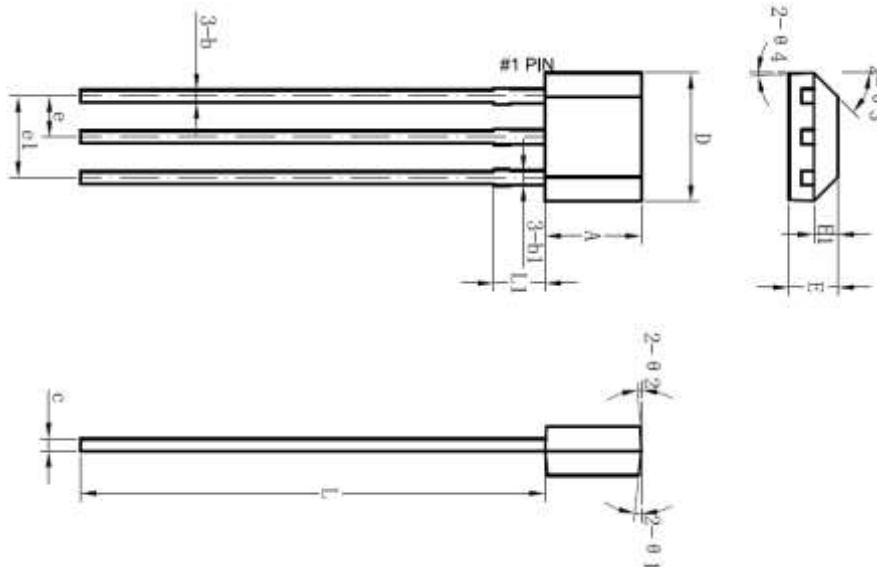

Symbol	Dimensions In Millimeters			Dimensions In Inches		
	Min.	Typ.	Max.	Min.	Typ.	Max.
A	2.90	3.00	3.10	0.11	0.12	0.12
b	0.35	0.39	0.56	0.01	0.02	0.02
b1		0.44			0.02	
c	0.36	0.38	0.51	0.01	0.01	0.02
D	3.9	4.0	4.2	0.15	0.16	0.16
E	1.42	1.52	1.62	0.06	0.06	0.06
E1		0.75			0.03	
e		1.27			0.05	
e1		2.54			0.10	
L	13.50	14.50	15.50	0.53	0.57	0.61
L1		1.60			0.06	
Θ1		6°			0.24°	
Θ2		3°			0.12°	
Θ3		45°			1.77°	
Θ4		3°			0.12°	



■ **Packing Information**

1)SOT23-3L

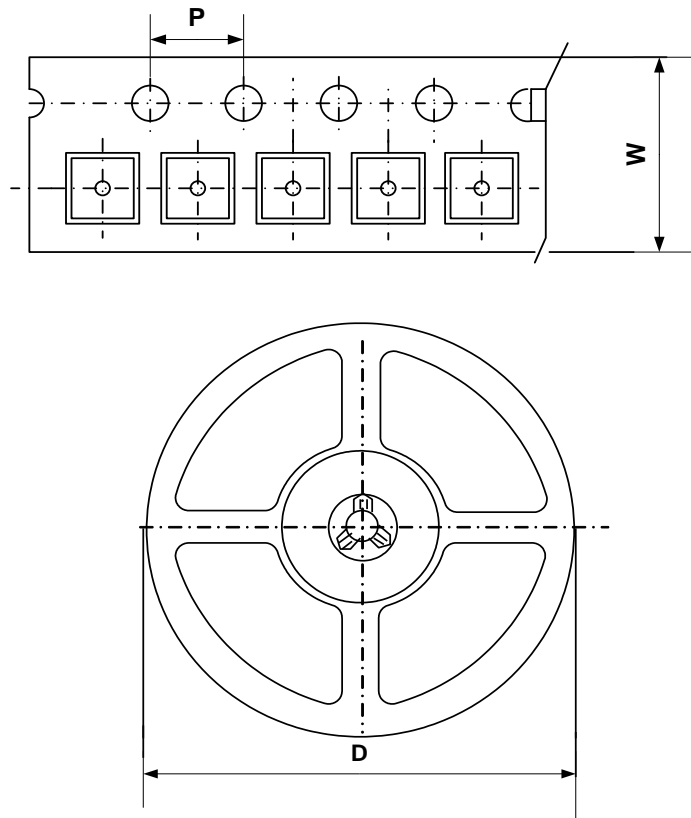

Package Type	Carrier Width (W)	Pitch (P)	Reel Size(D)	Packing Minimum
SOT23-3L	8.0±0.1 mm	4.0±0.1 mm	180±1 mm	3000pcs

Note: Carrier Tape Dimension, Reel Size and Packing Minimum

2)SIP-3L

1. Packing Type: Bag
2. Packing minimum: 1000pcs/Bag



IMPORTANT NOTICE

Orient-Chip Semiconductor Co., Ltd (OCS) and its subsidiaries reserve the right to make corrections, modifications, enhancements, improvements, and other changes to its products. Customers should obtain the latest relevant information before placing orders and should verify that such information is current and complete. These separate provisions won't be provided.

