

■ **General Description**

The OCH29801 is an integrated Hall sensor with H-Bridged output driver designed for brushless DC motor applications. The device is using HV process includes an on-chip Hall sensor for magnetic sensing, an amplifier that amplifies the Hall voltage, a comparator to provide switching hysteresis for noise rejection, a bi-directional drivers for sinking and driving large current load.

Placing the device in a variable magnetic field, if the magnetic flux density is larger than threshold BOP, the DO is turned to sink and DOB is turned to drive. This output state is held until the magnetic flux density reverses and falls below BRP, then causes DO to be turned to drive and DOB turned to sink.

OCH29801 is available in SOT23-6F package and is rated over the -40°C to 85°C.

■ **Features**

- One-chip Solution (Hall Element + Driver)
- Input Voltage Range: 3V to 20V
- Low Output Switching Current Noise
- Built-in VCC To GND reverse voltage protection
- High Sensitivity Hall Sensor
BOP (25GS), BRP (-25GS)
- Thermal Shutdown Protection
- -40°C to + 85°C Temperature Range
- RoHS Compliant
- Available in SOT23-6F package

■ **Applications**

- Single Coil Design Cooling Fans
- Single Coil DC Brushless Fan
- Single Coil DC Brushless Motor
- Office Automated Equipment
- Brown-Goods
- Home Applications
- Car Audio Cooling Fan

■ **Pin Configuration**



Figure 1, Pin Assignments Of OCH29801

Pin Name	Pin No.	Pin Function
NC	1	NC Pin
GND	2	Ground
DOB	3	Output 1
DO	4	Output 2
VDD	5、6	Positive Power Supply

■ **Typical Application Circuit**

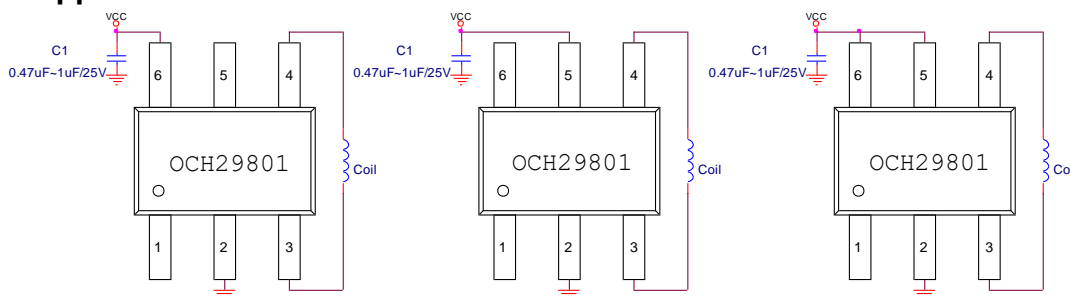

Note1: When the power pulse is relatively large, Must use least C1=0.47~1µF(ceramic capacitor) capacitor for the decoupling between VDD and GND and place the capacitor as close to the IC as Possible.

Figure 2, Typical Application Circuit of OCH29801



■ **Ordering Information**

Part Number	Output Current	Package Type	Packing Qty.	B _{OP} (Gauss)	B _{RP} (Gauss)	Temperature	Eco Plan	Lead
OCH29801TOAD	300mA	SOT23-6F	3000pcs /Reel	25(Typ.)	-25(Typ.)	-40~ +85°C	ROHS	Cu

■ **Block Diagram**

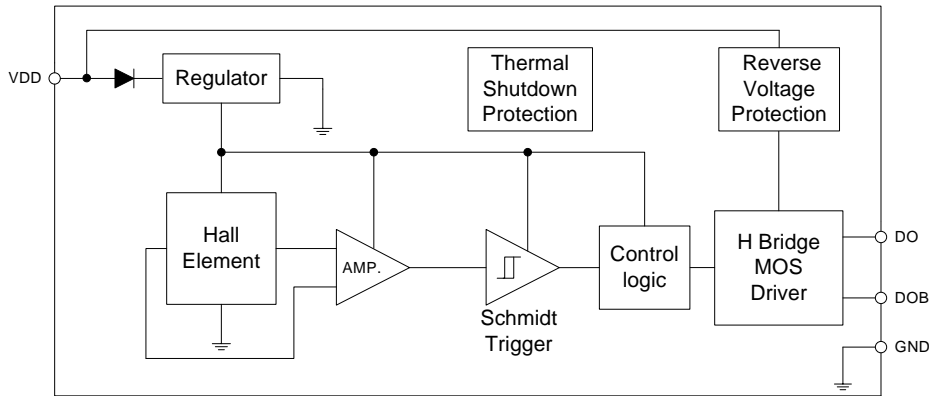

Figure 3, Block Diagram Of OCH29801



IMPORTANT NOTICE

Orient-Chip Semiconductor Co., Ltd. (OCS) and its subsidiaries reserve the right to make corrections, modifications, enhancements, improvements, and other changes to its products. Customers should obtain the latest relevant information before placing orders and should verify that such information is current and complete. These separate provisions won't be provided.

